



INSTALLATION GUIDE

BBT052/ BBC052/ BBCD052

WK2 JEEP GRAND CHEROKEE (2011 -)

Only fits Diesel Laredo without Quadratec Suspension



- Ironman 4x4 BBT/ BBC/ BBCD052 Bull Bars fit to a WK2 Grand Cherokee.
Only fits Diesel Laredo without Quadratec Suspension
- It will take about 4 hours to install.

NOTE: This product has been tested for air bag compatibility and therefore the mounting system MUST NOT be modified

IMPORTANT: Bull Bar installations should only be done by a qualified person and it is the responsibility of this person to ensure correct fitment.

1. Before installation check bull bar application is compatible with your vehicle.

2. Remove front bumper bar and padding



3. Locate and cutout cutting template at the end of this Instruction Guide.

4. Mask outer ends of bumper bar and place cutting template in position. Mark cut line and repeat for other side.



5. Refit bumper bar to vehicle using factory hardware.

6. Trim flare to suit bumper cut and install pinchweld.



7. Install winch cradle as shown reusing factory bolts (A, B & C).

Fit M10 bolts supplied to underside of cradle as shown.

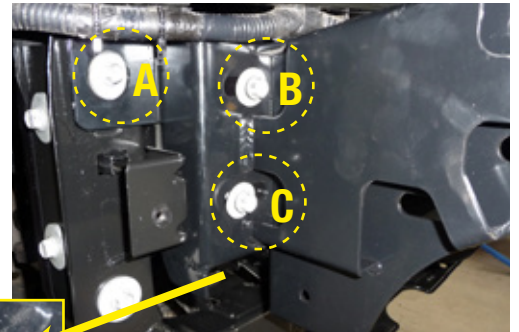
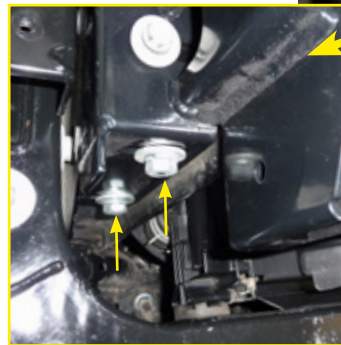

Note: Supplied spacer is installed between chassis and winch cradle mounting tab (see pic). M8 bolt supplied, feeds through from other side through plate, spacer and into factory thread

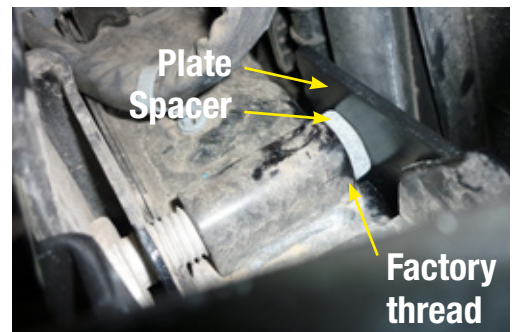

8. If winch is being installed, refer to winch installation instructions on page 5.
9. Unwrap bullbar. Check over riders and light assemblies are tight in bull bar before installation.
10. Fit bull bar to brackets using M12 hardware supplied. Do not tighten.

11. Align bull bar to vehicle and tighten mounting bolts.



12. Once bull bar is aligned with vehicle and tightened, drill through pinning holes (circled in red) between bull bar and chassis bracket and secure with bolts, washers and nuts provided.

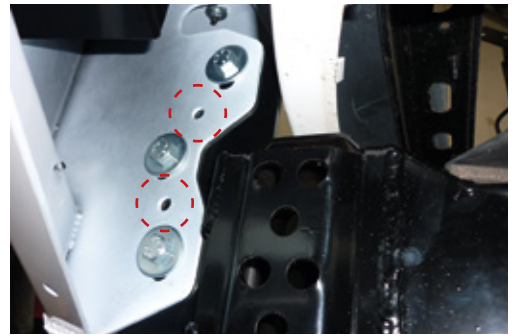

13. Connect park lights, indicators and fog lights as per wiring diagrams at the back of fitting instruction manual.

14. Fit protection plates and washer bottle guard underneath the bull bar using M8 bolts, spring washers and flat washers provided.



15. Trim guard liners and secure to protection plates using factory clips



Winch Installation

1. Before winch can be installed a section of the bumper bar will need to be removed. To do this, place winch on mounting cradle and mark bumper bar as shown.



2. Bolt winch to cradle with gearbox to the left hand side of vehicle and cable spooling from bottom of the cable drum using bolts and washers provided.



3. Bolt fairlead to recess in front of bull bar using bolts, washers and nuts provided.



4. Fit bull bar to vehicle referring to steps 12 - 17 of bull bar fitting instructions.

5. Mount control box in desired location.



6. Connect three colour coded cables to the corresponding poles on winch motor.



7. Connect the thin black earth wire and negative battery cable to the earth connection on the opposite side of winch motor.



8. Run the positive and negative battery cables into the engine bay taking care to secure cables away from any sharp or moving objects.

9. Connect positive and negative battery cables main battery of vehicle (Not Auxilliary Battery).

9. Attach breather hose to barb fitting on winch motor. Run hose to the highest available point in engine bay and cable tie in position. Cable tie hose away from any sharp, hot or moving objects.



Wiring Diagrams

PARK LIGHT & INDICATOR

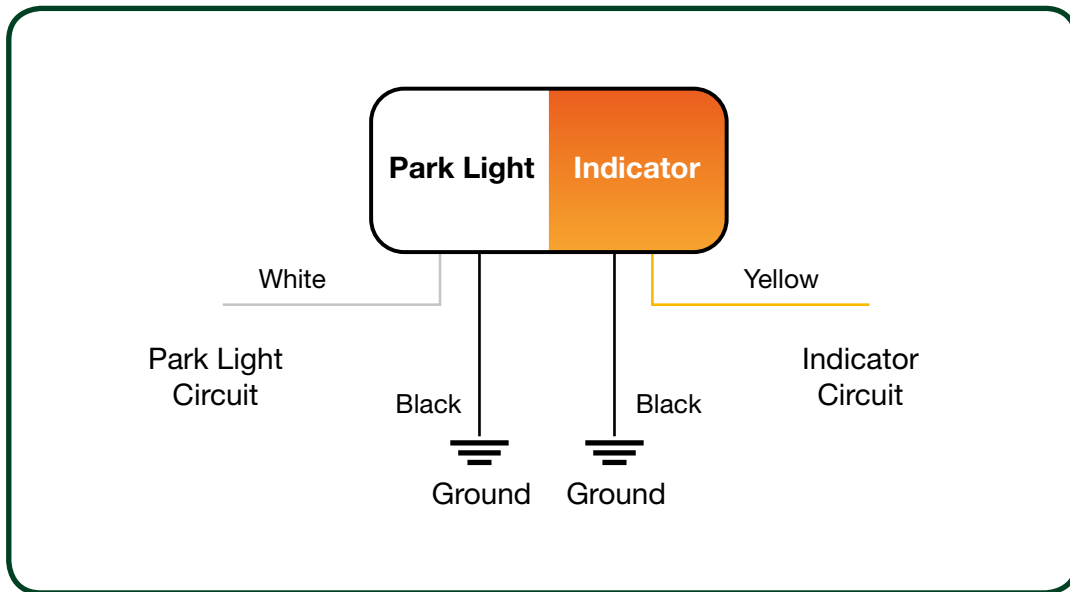

FOG LIGHTS

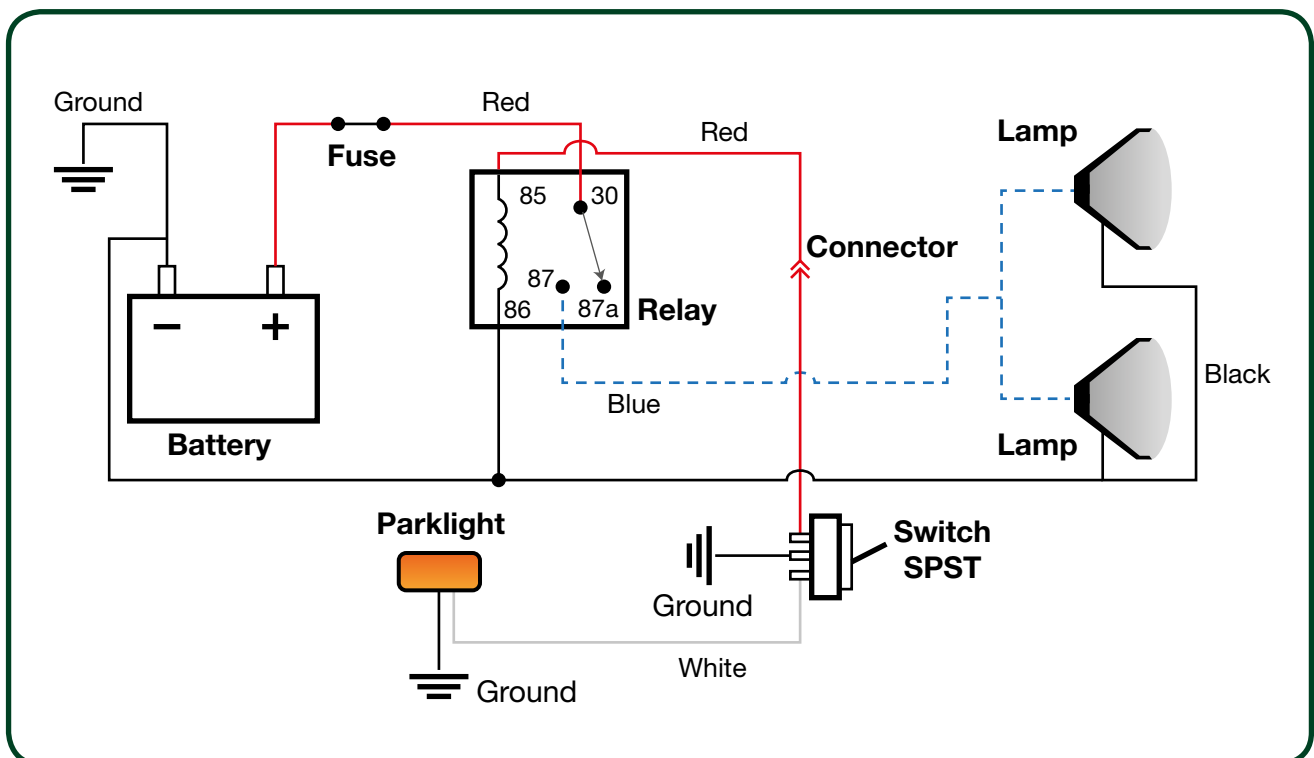



WK2 JEEP GRAND CHEROKEE 2011 -

Only fits Diesel Laredo without Quadratec Suspension

BBT052/ BBC052/ BBCD052

BULL BAR TEMPLATE



Registration Point



UNDER HEADLIGHT

TOWARD CENTRE OF VEHICLE



Registration Point

Registration Point



Registration Point

Registration Point



Registration Point

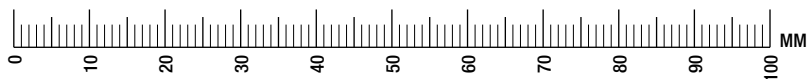

WK2 JEEP GRAND CHEROKEE 2011 -
Only fits Diesel Laredo without Quadratec Suspension
BBT052/ BBC052/ BBCD052
BULL BAR TEMPLATE

