



INSTALLATION GUIDE

BBT043/ BBC043/ BBCD043

TOYOTA LANDCRUISER
200 SERIES 2/2012+



- Ironman 4x4 BBT/ BBC/ BBCD043 Bull Bars fit to a Toyota Landcruiser 200 Series.
- It will take about 3 hours to install.

NOTE: This product has been tested for air bag compatibility and therefore the mounting system **MUST NOT** be modified

IMPORTANT: Bull Bar installations should only be done by a qualified person and it is the responsibility of this person to ensure correct fitment.

1. Before installation check bull bar application is compatible with your vehicle.

2. Remove number plate and grill and store in a safe place for later re-fitment.

3. Locate and cutout cutting template at the end of this Instruction Guide.

4. Mask outer ends of bumper bar and place cutting template in position in line with joint between bumper and mudguard, and wheel arch. Mark cut line and repeat for other side.



5. Mark a horizontal cut line across bumper, level with the top of the lower grill section and fog light housings as shown.



6. Remove bumper bar from vehicle.



7. Remove grill and fog light assemblies from bumper bar and cut along lines marked previously to remove lower section of bumper.

8. Remove aluminium bumper reinforcement and mounting brackets from chassis.



9. Remove recovery eyes and tie down points from chassis.



10. If your mounting cradle does not have an extra mounting hole as shown in pic A, refer to the measurements in pic B and drill a 14mm diameter hole as shown

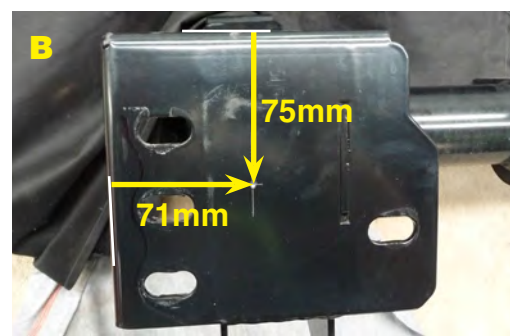
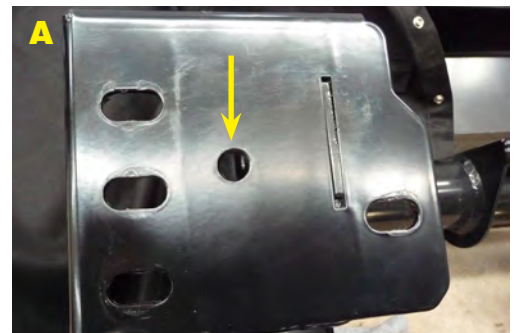

11. Attach mounting cradle to chassis as shown, reusing factory hardware.



12. Insert threaded anchorplate supplied, into the rectangle shaped hole in the side of the chassis as shown in pic A.

To do this, twist anchorplate on its side, push through chassis and twist anchorplate locking it vertically into position as shown in pic B. Threaded hole should now be towards outside of chassis.

Secure in position using M14 bolt and square plate and spring washer supplied through hole in mount plate, referred to in step 10. As shown in pic C.



13. Refit bumper.



14. Install pinch weld to ends of bumper.

15. If winch is being installed, refer to winch installation instructions Pages 7 - 8.

16. Unwrap bull bar. Check over riders and light assemblies are tight in bull bar before installation.

17. Fit bull bar to chassis brackets using M12 bolts, flat washers, spring washers and nuts provided.

18. Align bull bar with vehicle and tighten all bolts.



19. Once bull bar is aligned with vehicle and tightened, drill through pinning holes (circled in red) between bull bar and chassis bracket and secure with bolts, washers and nuts provided.



20. Connect park lights, indicators and fog lights as per wiring diagrams on page 9 of Instruction Guide.

21. Fit protection plates underneath the bull bar using M8 bolts, spring washers and flat washers provided.



22. Trim guard liners as shown.



Winch Installation

1. Bolt winch to cradle with gearbox to the left hand side of vehicle and cable spooling from bottom of the cable drum using bolts and washers provided.



2. Bolt fairlead to recess in front of bull bar using bolts, washers and nuts provided.



3. Fit bull bar to vehicle referring to steps of bull bar fitting instructions.

4. Mount control box in desired location.

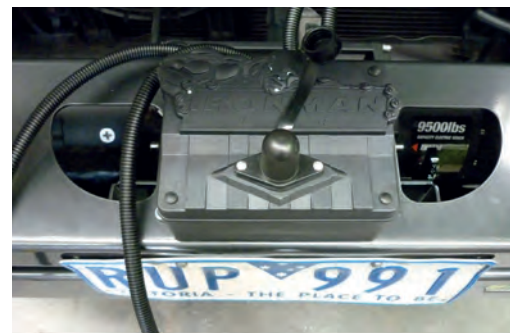

5. Connect three colour coded cables to the corresponding poles on winch motor.



6. Connect the thin black earth wire and negative battery cable to the earth connection on the opposite side of winch motor.



7. Run the positive and negative battery cables into the engine bay taking care to secure cables away from any sharp or moving objects.

8. Connect positive and negative battery cables main battery of vehicle (Not Auxilliary Battery).

9. Attach breather hose to barb fitting on winch motor. Run hose to the highest available point in engine bay and cable tie in position. Cable tie hose away from any sharp, hot or moving objects.



Wiring Diagrams

PARK LIGHT & INDICATOR

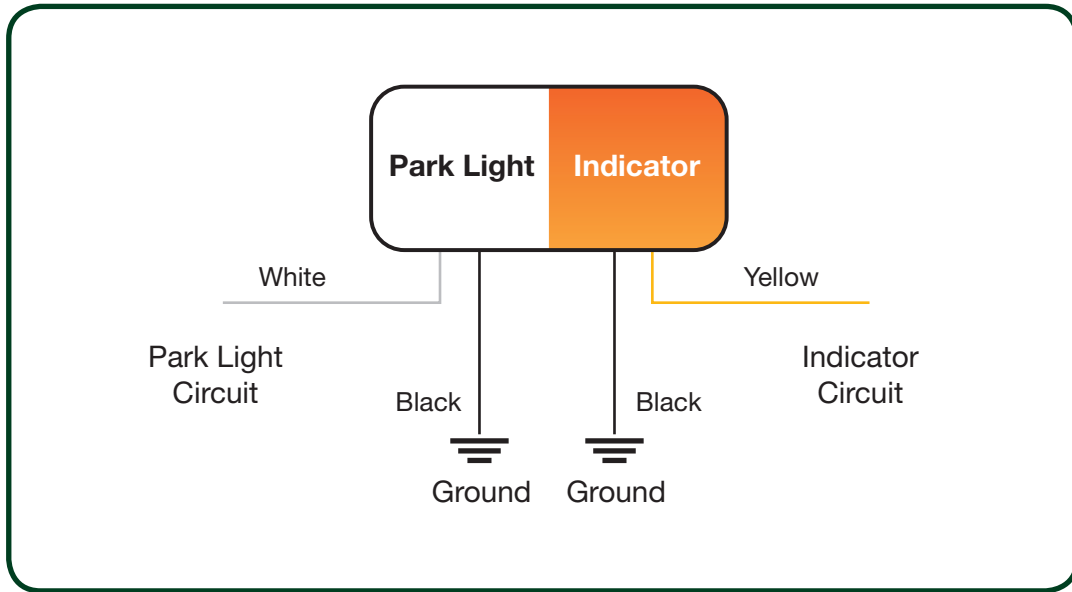

FOG LIGHTS

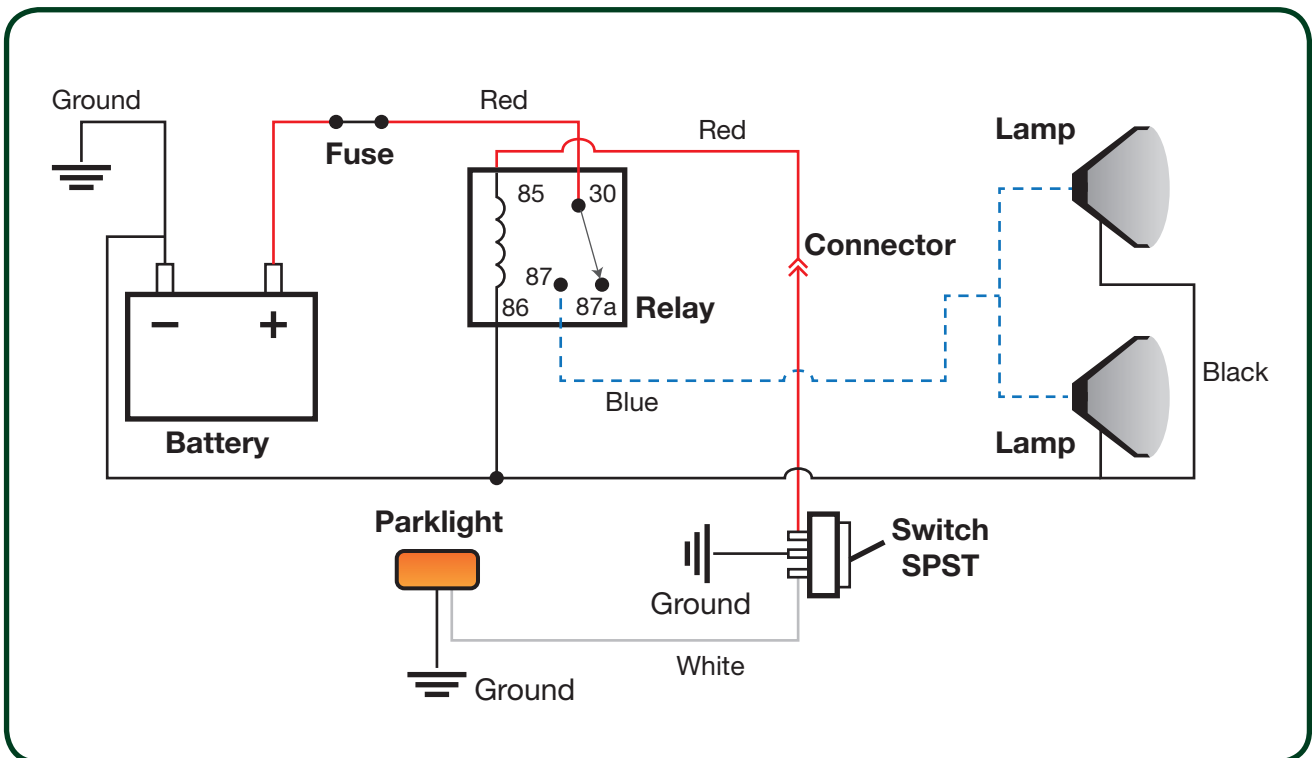

MUDGUARD

WHEEL ARCH

**RIGHT SIDE OF PAGE
CUT OUT TEMPLATE**

CUT

TEMPLATE B



**TOYOTA LANDCRUISER
200 SERIES (2/2012+)
BBA / BBT / BBC 043
BULL BAR TEMPLATE**

^ JOIN TEMPLATES A & B TOGETHER HERE



**TOYOTA LANDCRUISER
200 SERIES (2/2012+)
BBA / BBT / BBC 043
BULL BAR TEMPLATE**

TEMPLATE A

HEADLIGHT

To Front

**LEFT SIDE OF PAGE
CUT OUT TEMPLATE**

▲ JOIN TEMPLATES A & B TOGETHER HERE

▲ JOIN TEMPLATES A & C TOGETHER HERE

▶ JOIN TEMPLATES A & C TOGETHER HERE

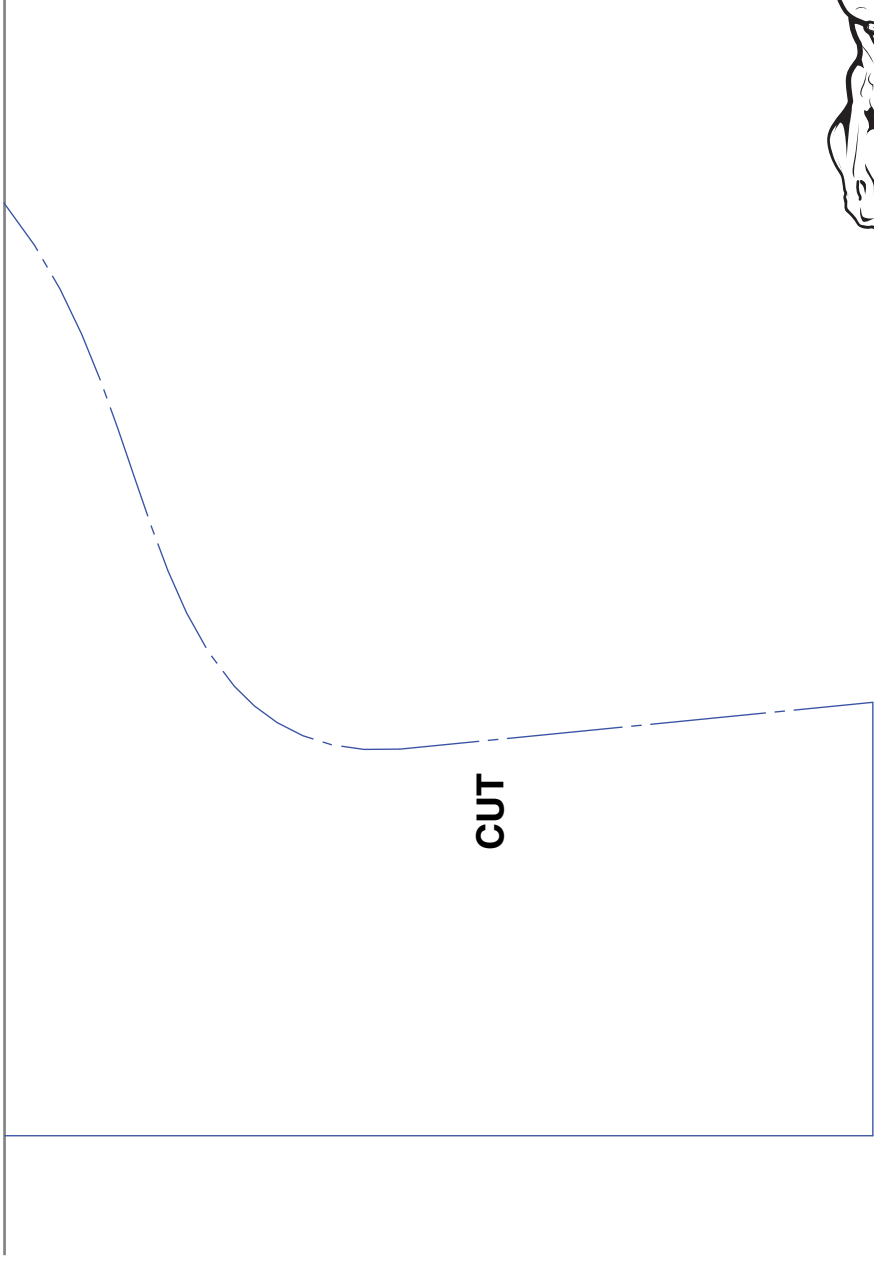

**TOYOTA LANDCRUISER
200 SERIES (2/2012+)
BBA / BBT / BBC 043
BULL BAR TEMPLATE**

TEMPLATE C